

# Cell Master™

## Model MT8212A

### Cable, Antenna and Base Station Analyzer

## MAINTENANCE MANUAL





## Table of Contents

1. Introduction . . . . .	1
2. Description . . . . .	1
3. VNA Frequency Accuracy . . . . .	1
4. VNA Return Loss Verification . . . . .	2
5. Spectrum Analyzer Frequency Accuracy . . . . .	2
6. Spectrum Analyzer Phase Noise Verification . . . . .	3
7. Spectrum Analyzer Second Harmonic Distortion Test . . . . .	5
8. Spectrum Analyzer Residual Spurious Response Test . . . . .	6
9. Spectrum Analyzer Resolution Bandwidth Accuracy Test . . . . .	7
10. Spectrum Analyzer Measurement Accuracy Verification . . . . .	10
11. Power Meter Verification (Option 29) . . . . .	18
12. T1/E1 Verification . . . . .	21
13. Termination Verification . . . . .	25
14. InstaCal Module Verification . . . . .	28
15. Battery Pack Removal and Replacement . . . . .	29
16. Battery Information . . . . .	30
17. Front Panel Assembly Removal and Replacement . . . . .	32
18. LCD Assembly Replacement . . . . .	33
19. Key Pad PCB Replacement . . . . .	34
20. Key Pad Membrane Replacement . . . . .	35
21. Main PCB Assembly Replacement . . . . .	35
22. Accessories and Replaceable Parts . . . . .	37
23. Customer Service . . . . .	38



## 1. Introduction

This manual provides maintenance instructions for the Cell Master Model MT8212A Cable, Antenna and Base Station Analyzer. It describes the product and provides performance verification procedures, parts replacement procedures, and a replaceable parts list.

## 2. Description

The Cell Master is a handheld SWR/RL (standing wave ratio/return loss), Distance-To-Fault, spectrum analysis, power meter and T1/E1 functional measurement instrument. It combines a synthesized source, VSWR Bridge, receiver, spectrum analyzer circuitry and T1/E1 interface testing circuitry in a compact instrument.

The following sections contain tests that can be used to verify the performance of the Cell Master Model MT8212A.

Throughout this manual, the term “VNA” denotes Return Loss, SWR, Cable Loss and DTF modes, and the term “SPA” denotes Spectrum Analyzer mode. All other modes are referenced individually.

## 3. VNA Frequency Accuracy

The following test can be used to verify the CW frequency accuracy of the Cell Master. Measurement calibration of the Cell Master is not required for this test.

### a. Equipment Required:

- Spectrum Analyzer Anritsu Model MS2665C or equivalent
- 10 MHz Reference Standard

### b. Procedure:

1. Connect a 10 MHz Reference signal to the 10 MHz STD Ref In of the MS2665C or equivalent.
2. Press and hold the **ESCAPE/CLEAR** key, then press the **ON/OFF** key to turn on the Cell Master. (This sets the instrument to the factory preset state.)

*NOTE: Before continuing, allow a five minute warm up for the internal circuitry to stabilize.*

3. Press the **FREQ/DIST** key, then press the F1 soft key and set F1 to 1000 MHz, then press the **ENTER** key.
4. Press the F2 soft key, set F2 to 1000 MHz, then press the **ENTER** key.
5. Press the **MEAS/DISP** key, then press the Fixed CW soft key to turn Fixed CW On.
6. Connect the RF cable from the Cell Master Reflection Test Port to the RF Input on the MS2665C or equivalent.
7. Set up the MS2665C as follows:
  - (a) Press the **Preset** key, then select **Preset All** (F1).
  - (b) Press the **Frequency** key.
  - (c) Press the **1** key and then the **GHz** key to change the Center Frequency to 1 GHz.
  - (d) Press the **Span** key.
  - (e) Press the **7, 5, 0,** and **kHz** keys sequentially to change the Frequency Span to 750 kHz.
  - (f) Press the **RBW** key.
  - (g) Press the **1, 0** and **kHz** keys sequentially to change the RBW to 10 kHz.
  - (h) Press the **VBW** key.
  - (i) Press the **Filter Off** soft key (F3) to turn the VB filter off.

- (j) Press the **Amplitude** key.
- (k) Press the **0**, and **dBm** keys sequentially to change the Reference Level to 0 dBm.
- (l) Press the **Log Scale** soft key (F5)
- (m) Select **2 dB/Div** (F3) and then press the **return** soft key.

*NOTE: If the Cell Master has gone into the hold mode, press the **RUN/HOLD** key to return to normal mode.*

8. When a peak response appears on the Spectrum Analyzer, press the **Marker Peak Search** key on the Spectrum Analyzer. Verify that the marker peak readout value is 1000 MHz  $\pm$  75 kHz.
9. On the Cell Master, press the **MEAS/DISP** key then the Fixed CW soft key to turn Fixed CW off.

#### 4. VNA Return Loss Verification

The following test can be used to verify the accuracy of return loss measurements. Measurement calibration of the Cell Master is required for this test.

a. Equipment Required:

- 20 dB offset, Anritsu SC5270
- 6 dB offset, Anritsu SC5237
- Open/Short, Anritsu 22N50
- 50 Ohm Termination, Anritsu 28N50-2 or SM/PL

b. Procedure:

1. Press and hold the **ESCAPE/CLEAR** key, then press the **ON/OFF** key to turn on the Cell Master. (This sets the instrument to the factory preset state.)

*NOTE: Before continuing, allow a five minute warm up for the internal circuitry to stabilize.*

2. Press the **MODE** key.
3. Use the Up/Down arrow key to highlight Return Loss, then press **ENTER**.
4. Press the **START CAL** key.
5. Follow the instructions on the screen to perform a calibration using a 22N50 Open/Short and 28N50-2 or SM/PL Termination.
6. Connect the 20 dB offset to the Refl Test Port and verify that the reading is 20 dB  $\pm$  1.7 dB.
7. Connect the 6 dB offset to the Refl Test Port and verify that the reading is 6 dB  $\pm$  1.2 dB.

#### 5. Spectrum Analyzer Frequency Accuracy

The following test can be used to verify the CW frequency accuracy of the Cell Master Spectrum Analyzer.

a. Equipment Required:

- Anritsu MG3692A Synthesized Signal Source, with option 15A or equivalent
- Anritsu 34RSN50 50 ohm adapter or equivalent
- Anritsu 15NNF50-1.5C RF Coaxial Cable or equivalent
- 10 MHz Reference Standard
- BNC male to BNC male coaxial cable

b. Procedure:

1. Connect the 10 MHz reference source to the Anritsu MG3692A Synthesized Signal Source.
2. Connect the output of the source to the RF Input of the Cell Master.
3. Connect the external power supply (Anritsu part number 40-163) to the Cell Master.
4. Press and hold the **ESCAPE/CLEAR** key, then press the **ON/OFF** key to turn on the Cell Master. (This sets the instrument to the factory preset state.)
5. Turn on the 10 MHz reference source and the Anritsu MG3692A Synthesized Signal Source.
6. Set the MG3692A output to 2000 MHz CW, with an RF output level of 0 dBm.

*NOTE: Before continuing, allow a 30-minute warm up for the internal circuitry to stabilize.*

7. On the Cell Master, press the **MODE** key. Use the up/down arrow key to highlight Spectrum Analyzer and press **ENTER** to select spectrum analyzer mode.
8. Press the **AMPLITUDE** key and the Ref Level soft key.
9. Enter 20 and press the **ENTER** key to set the Reference Level to 20 dBm.
10. Press the **FREQ/DIST** key and the Center soft key.
11. Enter 2000 and press **ENTER** to set the center frequency to 2000 MHz.
12. Press the Span soft key, enter 20, and press the kHz soft key to set the span to 20 kHz.
13. Confirm that the RBW is 100 Hz, and the VBW is 30 Hz. If adjustment of the RBW and VBW are required:
  - (a) Press the **MEAS/DISP** key and the Bandwidth soft key.
  - (b) Press the RBW Manual soft key and use the Up/Down arrow key to select 100 Hz. Press **ENTER** to set the resolution bandwidth to 100 Hz.
  - (c) Press the VBW Manual soft key and use the Up/Down arrow key to select 30 Hz. Press **ENTER** to set the video bandwidth to 30 Hz.
14. Press the **MARKER** key, then the M1 soft key.
15. Select the Edit soft key and use the Up/Down arrow key to center the marker on the waveform. Verify that the marker frequency is 2000 MHz  $\pm$  4 kHz.

## 6. Spectrum Analyzer Phase Noise Verification

This test can be used to verify the phase noise of the Cell Master Spectrum Analyzer.

a. Equipment Required:

- Anritsu MG3692A Synthesized Signal Source, with options 2A, 4 and 15A, or equivalent
- Anritsu 34RSN50 50 ohm adapter or equivalent
- Anritsu 15NNF50-1.5C RF Coaxial Cable or equivalent

b. Procedure:

1. Connect the output of the source to the Cell Master RF Input.
2. Connect the external power supply (Anritsu part number 40-163) to the Cell Master.
3. Press and hold the **ESCAPE/CLEAR** key, then press the **ON/OFF** key to turn on the Cell Master. (This sets the instrument to the factory preset state.)

*NOTE: Before continuing, allow a 30-minute warm up for the internal circuitry to stabilize.*

4. Set the MG3692A output to 1000 MHz CW, with an RF output level of -30 dBm.

5. On the Cell Master, press the **MODE** key. Use the Up/Down arrow key to highlight Spectrum Analyzer, then, press the **ENTER** key to select spectrum analyzer mode.
6. Press the **MEAS/DISP** key and the Bandwidth soft key.
7. Press the RBW Manual soft key and use the Up/Down arrow key to select 1 kHz. Press **ENTER** to set the resolution bandwidth to 1 kHz.
8. Press the VBW Manual soft key and use the Up/Down arrow key to select 30 Hz. Press **ENTER** to set the video bandwidth to 30 Hz.
9. Press the **FREQ/DIST** key and the CENTER soft key.
10. Enter 1000 and press the **ENTER** key to set the center frequency to 1000 MHz.
11. Press the **SPAN** soft key and enter 0.1. Press the **ENTER** key to set the span to 0.100 MHz.
12. Press the **AMPLITUDE** key.
13. Press the REF LEVEL soft key and enter -27. Press **ENTER** to set the reference level to -27 dBm.
14. Press the **MARKER** key, then the M1 soft key.
15. Press EDIT and enter 1000. Press **ENTER** to set the M1 marker frequency to 1000 MHz.
16. Press the BACK soft key and the M2 soft key.
17. Press EDIT and enter 1000.03. Press **ENTER** to set the M2 marker frequency to 1000.03 MHz (30 kHz higher than the center frequency).
18. Press the DELTA (M2-M1) soft key.
19. Press the **RUN/HOLD** key and read and record the  $\Delta 2$  reading
20. Press the **RUN/HOLD** key to read and record five values, then calculate the average of the five recorded values.
21. Subtract 30 dB from the average value and verify that the result is  $\leq -75$  dBc/Hz. (For example: -45 dBc measured - 30 dB = -75 dBc/Hz.)

*NOTE: The measured value is converted to dBc/Hz using the following formula:*

$$dBc / Hz = - |measured dBc| - \left[ 10_{\log} \left( \frac{RBW}{1Hz} \right) \right]$$

*At 1 kHz RBW,  $10_{\log} \left( \frac{RBW}{1Hz} \right) = 30$ , so  $dBc / Hz = - |measured dBc| - 30$ .*

22. Press the **BACK** soft key and the M3 soft key.
23. Press the EDIT key and enter 999.97. Press MHz to set the M3 marker frequency to 999.97 MHz (30 kHz lower than the center frequency).
24. Press the DELTA (M3-M1) soft key.
25. Press the **RUN/HOLD** key. Read and record the  $\Delta 3$  reading.
26. Press the **RUN/HOLD** key to read and record five values, then calculate the average of the five recorded values.
27. Subtract 30 dB from the average value and verify that the result is  $\leq -75$  dBc/Hz. (For example: -45 dBc measured - 30 dB = -75 dBc/Hz.)



## 7. Spectrum Analyzer Second Harmonic Distortion Test

The following test can be used to verify the input related spurious response of the Cell Master Spectrum Analyzer.

### a. Equipment Required:

- Anritsu MG3692A Synthesized Signal Source with options 2A, 4 and 15A, or equivalent
- Anritsu 34RSN50 50 ohm adapter or equivalent
- Anritsu 15NNF50-1.5C RF Coaxial Cable or equivalent
- 10 MHz Reference Standard
- 50 MHz Low Pass Filter (Anritsu part number 1030-96)
- BNC male to BNC male coaxial cable

### b. Procedure:

1. Connect the 10 MHz reference source to the Anritsu MG3692A Synthesized Signal Source.
2. Connect one end of the 50 MHz Low Pass Filter to the output of the source and the other end to the Cell Master Spectrum Analyzer RF Input with the coaxial cable.
3. Connect the external power supply (Anritsu part number 40-163) to the Cell Master.
4. On the Cell Master, press and hold the **ESCAPE/CLEAR** key, then press the **ON/OFF** key to turn on the Cell Master. (This sets the instrument to the factory preset state.)
5. Turn on the 10 MHz reference source and the Anritsu MG3692A Synthesized Signal Source.
6. Set the MG3692A output to 40 MHz CW, with an RF output level of  $-30$  dBm.

*NOTE: Before continuing, allow a 30-minute warm up for the internal circuitry to stabilize.*

7. On the Cell Master, press the **MODE** key. Use the Up/Down arrow key to highlight Spectrum Analyzer, then, press the **ENTER** key to select spectrum analyzer mode.
8. Press the **AMPLITUDE** key and the Ref Level soft key.
9. Enter  $-27$  and press the **ENTER** key to set the Reference Level to  $-27$  dBm.
10. Press the **Scale** soft key and enter 7 then press **ENTER**.
11. Press the **FREQ/DIST** key and then the Center soft key.
12. Enter 40 and press the MHz soft key to set the center frequency to 40 MHz.
13. Press the **Span** soft key and enter 0.2. Press the MHz soft key to set the span to 0.200 MHz.
14. Press the **MEAS/DISP** key and the Bandwidth soft key.
15. Press the **RBW Manual** soft key and use the Up/Down arrow key to select 10 kHz. Press **ENTER** to set the resolution bandwidth to 10 kHz.
16. Press the **VBW Manual** soft key and use the Up/Down arrow key to select 3 kHz. Press **ENTER** to set the video bandwidth to 3 kHz.
17. Press the **MARKER** key, then the M1 soft key.
18. Select the **Edit** soft key, then enter 40. Press the MHz soft key to set M1 to 40 MHz.
19. On the MG3692A Synthesized Signal Source, adjust the output level so that the M1 reading of Cell Master Spectrum Analyzer is  $-30$  dBm at 40 MHz.
20. On the Cell Master, press the **FREQ/DIST** key and then the Center soft key.
21. Enter 80 and press the MHz soft key to set the center frequency to 80 MHz.
22. Press the **MARKER** key and the M1 soft key.

23. Select the Edit soft key, then enter 80. Press the MHz soft key to set M1 to 80 MHz .

24. Record the amplitude of the signal at M1 80 MHz:

Second Harmonic Level @ 80 MHz = \_\_\_\_\_ dBm

25. Convert this measured value to dBc using the following formula:

Input Related Spurious Response (dBc) = [Second Harmonic Level @ 80 MHz]  
+ 30 dBm = \_\_\_\_\_ dBc

Specifications for this measurement are –45 dBc with –30 dBm into the first mixer.

## 8. Spectrum Analyzer Residual Spurious Response Test

The following test can be used to verify the residual spurious response of the Cell Master Spectrum Analyzer.

a. Equipment Required:

- Anritsu 28N50-2 or SM/PL 50 ohm Termination or equivalent

b. Procedure:

1. Connect the 50 ohm termination to the Cell Master RF Input.
2. On the Cell Master, press and hold the **ESCAPE/CLEAR** key, then press the **ON/OFF** key to turn on the Cell Master. (This sets the instrument to the factory preset state.)

*NOTE: Before continuing, allow a 30-minute warm up for the internal circuitry to stabilize.*

3. On the Cell Master, press the **MODE** key. Use the Up/Down arrow key to highlight Spectrum Analyzer, then, press the **ENTER** key to select spectrum analyzer mode.
4. Press the **AMPLITUDE** key and the Ref Level soft key.
5. Enter –75 and press the **ENTER** key to set the Reference Level to –75 dBm.
6. Press the Scale soft key and enter 5, then press **ENTER**.
7. Press the **MEAS/DISP** key and the Bandwidth soft key.
8. Press the RBW Manual soft key and use the Up/Down arrow key to select 10 kHz. Press **ENTER** to set the resolution bandwidth to 10 kHz.
9. Press the VBW Manual soft key and use the Up/Down arrow key to select 3 kHz and press **ENTER** to set the video bandwidth to 3 kHz.
10. Press the **FREQ/DIST** key and the Start soft key.
11. Enter 10 and press the MHz soft key to set the start frequency to 10 MHz.
12. Press the Stop soft key and enter 1000, then press the MHz soft key to set the stop frequency to 1000 MHz.
13. Wait till one full sweep is complete.
14. Press the **MARKER** key and then the M1 soft key.
15. Press the On/Off soft key and then the Marker To Peak soft key.
16. Record the M1 amplitude reading and verify whether it is less than or equal to –90 dBm.

*NOTE: If a spur with an amplitude larger than –90 dBm occurs, wait another full sweep and observe whether the spur occurs at the same point on the second sweep. If the spur does not occur at the same point on the second sweep, then the spur on the first sweep was not real.*

17. Press the **FREQ/DIST** key and the Start soft key.

18. Enter 1000 and press the MHz soft key to set the start frequency to 1000 MHz.
19. Press the Stop soft key and enter 2000, then press the MHz soft key to set the stop frequency to 2000 MHz.
20. Wait until one full sweep is complete.
21. Press the **MARKER** key and then the M1 soft key.
22. Press the On/Off soft key and then the Marker To Peak soft key.
23. Record the M1 amplitude reading and verify it is  $\leq -90$  dBm.
24. Press the **FREQ/DIST** key and the Start soft key.
25. Enter 2000 and press the MHz soft key to set the start frequency to 2000 MHz.
26. Press the Stop soft key and enter 3000, then press the MHz soft key to set the stop frequency to 3000 MHz.
27. Wait until one full sweep is complete.
28. Press the **MARKER** key and then the M1 soft key.
29. Press the On/Off soft key and then the Marker To Peak soft key.
30. Record the M1 amplitude reading and verify it is  $\leq -90$  dBm.

## 9. Spectrum Analyzer Resolution Bandwidth Accuracy Test

The following test can be used to verify the resolution bandwidth accuracy of the Cell Master Spectrum Analyzer at different frequencies.

### a. Equipment Required:

- Anritsu MG3692A Synthesized Signal Source with options 2A, 4 and 15, or equivalent
- Anritsu 34RSN50 50 ohm adapter or equivalent
- Anritsu 15NNF50-1.5C RF Coaxial Cable or equivalent
- 10 MHz Reference Standard
- BNC male to BNC male coaxial cable

### b. Procedure:

1. Connect the 10 MHz reference source to the Anritsu MG3692A Synthesized Signal Source.
2. Connect the output of the Anritsu MG3692A Synthesized Signal Source to the Cell Master Spectrum Analyzer RF Input.
3. On the Cell Master, press and hold the **ESCAPE/CLEAR** key, then press the **On/Off** key to turn on the Cell Master. (This sets the instrument to the factory preset state.)

*NOTE: Before continuing, allow a 30-minute warm up for the internal circuitry to stabilize.*

4. Set the MG3692A output to 1 GHz, with an RF output level of  $-30$  dBm.
5. On the Cell Master, press the **MODE** key. Use the Up/Down arrow key to highlight Spectrum Analyzer, then, press the **ENTER** key to select spectrum analyzer mode.
6. Press the **AMPLITUDE** key and the Ref Level soft key.
7. Enter  $-27$  and press the **ENTER** key to set the Reference Level to  $-27$  dBm.
8. Press the Scale soft key and enter 3, then press **ENTER**.
9. Press the **FREQ/DIST** key and the Center soft key.
10. Enter 1 and press the GHz soft key to set the center frequency to 1 GHz.

*NOTE: The Measured Occupied BW value for each RBW setting can be recorded in Table 1, page 10.*

### 1 MHz RBW Test

11. Press the **Span** soft key, enter 1.5 and press the **MHz** soft key to set the span to 1.5 MHz.
12. Press the **MEAS/DISP** key and the **Bandwidth** soft key.
13. Press the **RBW Manual** soft key and use the Up/Down arrow key to select 1 MHz. Press **ENTER** to set the resolution bandwidth to 1 MHz.
14. Press the **VBW Manual** soft key and use the Up/Down arrow key to select 3 kHz and press **ENTER** to set the video bandwidth to 3 kHz and select **BACK**.
15. Press the **Measure** soft key, the **OBW** soft key, the **dBc** soft key, and then the **ENTER** key.
16. Press the **Measure** soft key, then the **MARKER** key. Press the **M2** soft key and then the **Delta (M2-M1)** soft key. The displayed  $\Delta 2$  frequency should be  $\pm 5\%$  of the RBW.

### 300 kHz RBW Test

17. Press the **FREQ/DIST** key.
18. Press the **Span** soft key, enter 450 and press the **kHz** soft key to set the span to 450 kHz.
19. Press the **MEAS/DISP** key and the **Bandwidth** soft key.
20. Press the **RBW Manual** soft key and use the Up/Down arrow key to select 300 kHz. Press **ENTER** to set the resolution bandwidth to 300 kHz and select **BACK**.
21. Press the **Measure** soft key and then the **MARKER** key.
22. Press the **M2** soft key. The displayed  $\Delta 2$  frequency should be  $\pm 5\%$  of the RBW.

### 100 kHz RBW Test

23. Press the **FREQ/DIST** key.
24. Press the **Span** soft key, enter 150 and press the **kHz** soft key to set the span to 150 kHz.
25. Press the **MEAS/DISP** key and the **Bandwidth** soft key.
26. Press the **RBW Manual** soft key and use the Up/Down arrow key to select 100 kHz. Press **ENTER** to set the resolution bandwidth to 100 kHz and select **BACK**.
27. Press the **Measure** soft key and then the **MARKER** key.
28. Press the **M2** soft key. The displayed  $\Delta 2$  frequency should be  $\pm 5\%$  of the RBW.

### 30 kHz RBW Test

29. Press the **FREQ/DIST** key.
30. Press the **Span** soft key, enter 45 and press the **kHz** soft key to set the span to 45 kHz.
31. Press the **MEAS/DISP** key and the **Bandwidth** soft key.
32. Press the **RBW Manual** soft key and use the Up/Down arrow key to select 30 kHz. Press **ENTER** to set the resolution bandwidth to 30 kHz and select **BACK**.
33. Press the **Measure** soft key to measure the bandwidth, then press the **MARKER** key.
34. Press the **M2** soft key. The displayed  $\Delta 2$  frequency should be  $\pm 5\%$  of the RBW.

### 10 kHz RBW Test

35. Press the **FREQ/DIST** key.
36. Press the **Span** soft key, enter 15 and press the **kHz** soft key to set the span to 15 kHz.
37. Press the **MEAS/DISP** key and the **Bandwidth** soft key.
38. Press the **RBW Manual** soft key and use the Up/Down arrow key to select 10 kHz. Press **ENTER** to set the resolution bandwidth to 10 kHz and select **BACK**.

39. Press the VBW Manual soft key and use the Up/Down arrow key to select 30 Hz. Press **ENTER** to set the video bandwidth to 30 Hz and select **BACK**.
40. Press the Measure soft key, then the **MARKER** key.
41. Press the M2 soft key. The displayed  $\Delta 2$  frequency should be  $\pm 5\%$  of the RBW.

#### 3 kHz RBW Test

42. Press the **FREQ/DIST** key.
43. Press the Span soft key, enter 4.5 and press the kHz soft key to set the span to 4.5 kHz.
44. Press the **MEAS/DISP** key and the Bandwidth soft key.
45. Press the RBW Manual soft key and use the Up/Down arrow key to select 3 kHz. Press **ENTER** to set the resolution bandwidth to 3 kHz and select **BACK**.
46. Press the Measure soft key to measure the bandwidth, then press the **MARKER** key.
47. Press the M2 soft key. The displayed  $\Delta 2$  frequency should be  $\pm 5\%$  of the RBW.

#### 1 kHz RBW Test

48. Press the **FREQ/DIST** key.
49. Press the Span soft key, enter 1.5 and press the kHz soft key to set the span to 1.5 kHz.
50. Press the **MEAS/DISP** key and the Bandwidth soft key.
51. Press the RBW Manual soft key and use the Up/Down arrow key to select 1 kHz. Press **ENTER** to set the resolution bandwidth to 1 kHz and select **BACK**.
52. Press the Measure soft key then the **MARKER** key.
53. Press the M2 soft key. The displayed  $\Delta 2$  frequency should be  $\pm 5\%$  of the RBW.

#### 300 Hz RBW Test

54. Press the **FREQ/DIST** key.
55. Press the Span soft key, enter 450 and press the Hz soft key to set the span to 450 Hz.
56. Press the **MEAS/DISP** key and the Bandwidth soft key.
57. Press the RBW Manual soft key and use the Up/Down arrow key to select 1 kHz. Press **ENTER** to set the resolution bandwidth to 300 Hz and select **BACK**.
58. Press the Measure soft key then the **MARKER** key.
59. Press the M2 soft key. The displayed  $\Delta 2$  frequency should be  $\pm 5\%$  of the RBW.

#### 100 Hz RBW Test

60. Press the **FREQ/DIST** key.
61. Press the Span soft key, enter 150 and press the Hz soft key to set the span to 150 Hz.
62. Press the **MEAS/DISP** key and the Bandwidth soft key.
63. Press the RBW Manual soft key and use the Up/Down arrow key to select 100 Hz. Press **ENTER** to set the resolution bandwidth to 100 Hz and select **BACK**.
64. Press the Measure soft key then the **MARKER** key.

65. Press the M2 soft key. The displayed  $\Delta 2$  frequency should be  $\pm 5\%$  of the RBW.

Table 1. RBW Check

RBW Setting	Lower Limit	Measured Value	Upper Limit
1 MHz	0.95 MHz		1.05 MHz
300 kHz	285 kHz		315 kHz
100 kHz	95 kHz		105 kHz
30 kHz	28.5 kHz		31.5 kHz
10 kHz	9.5 kHz		10.5 kHz
3 kHz	2.85 kHz		3.15 kHz
1 kHz	0.95 kHz		1.05 kHz
300 Hz	285 Hz		315 Hz
100 Hz	95 Hz		105 Hz

## 10. Spectrum Analyzer Measurement Accuracy Verification

The tests in this section verify the level accuracy of the Cell Master Spectrum Analyzer. There are two parts to this test:

- Level Accuracy with Frequency Test
- Level Accuracy with Power Test

### Level Accuracy with Frequency Test

#### a. Equipment Required:

- Anritsu MG3692A Synthesized Signal Source, with options 2A, 4 and 15A
- Anritsu ML2438A Dual Channel Power Meter or equivalent
- Anritsu MA2442A High Accuracy Power Sensors or equivalent (2)
- Anritsu N241A50 Power Splitter or equivalent
- Anritsu 34NN50A 50 ohm adapter or equivalent
- Anritsu 34RSN50 50 ohm adapter or equivalent
- Anritsu 34RKNF50 50 ohm adapter or equivalent
- Anritsu 15NNF50-1.5C RF Coaxial Cable or equivalent
- Weinschel 1-10 10 dB Fixed Attenuator

#### b. Procedure

1. Turn on the power meter and signal source.

*NOTE: Before continuing, allow a 30-minute warm up for the internal circuitry to stabilize.*

2. On the power meter, press the Channel key, the Setup soft key and then the CHANNEL soft key to display Channel 2 setup menu. Press the INPUT key twice to set the Input Configuration to B. Press the Sensor key to display both Sensor A and Sensor B readings.
3. Connect the power sensors to the power meter and calibrate the sensors.
4. Set the MG3692A output power level to 5 dBm.
5. Set the MG3692A output to 30 MHz CW.

6. On the power meter, press the Sensor key, the Cal Factor soft key, and then the FREQ soft key. Use the keypad to enter 30 MHz as the input signal frequency, which sets the power meter to the proper power sensor cal factor. Press the SENSOR key on the power meter to display the power reading.
7. Connect Sensor A to the MG3692A output, measure the output power level and record the value in column A of Table 2.
8. Disconnect Sensor A from the MG3692A output.
9. Connect the power splitter to the MG3692A output and Sensor B to one of the power splitter outputs. Install the 10 dB Fixed Attenuator to the other power splitter output and then connect Sensor A to the end of the Attenuator. Refer to Figure 1.
10. Record the new sensor A reading in column B of Table 2.
11. Record the Sensor B reading in column D of Table 2.
12. Calculate the Splitter/Attenuator Combined Loss using the following formula and record the result in column C of Table 2:  $C = A - B$
13. Calculate the Sensor B path Power Splitter Loss using the following formula and record the result in column E of Table 2:  $E = A - D$
14. Repeat steps 5 through 13 for 50 MHz, 550 MHz, 1000 MHz, 1244 MHz, 1411 MHz, 2000 MHz, 2512 MHz, 2850 MHz and 2925 MHz.

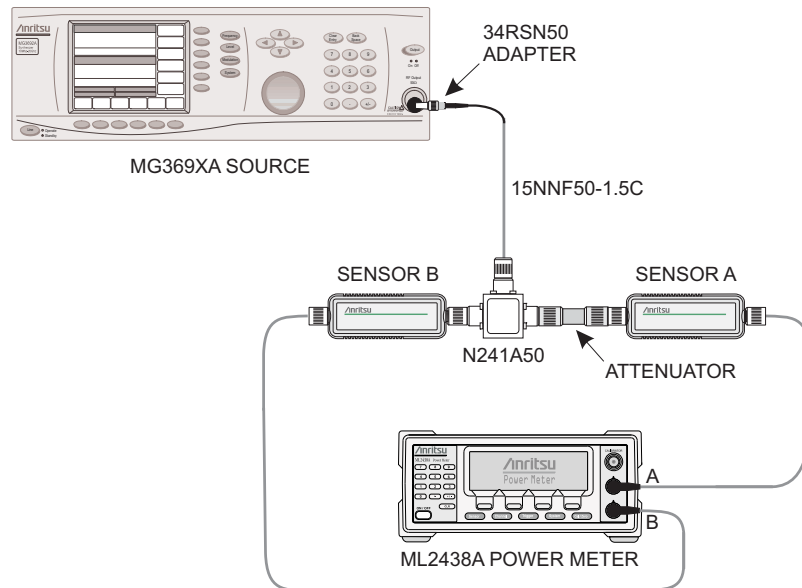

Figure 1. Level Accuracy with Frequency Test Setup

Table 2. Output Power Level

	<b>A</b>	<b>B</b>	<b>C</b>	<b>D</b>	<b>E</b>
<b>Freq (MHz)</b>	<b>Sensor A Reading @ Source Output</b>	<b>Sensor A Reading @ end of Attenuator</b>	<b>Splitter/Attenuator Combined Loss</b>	<b>Sensor B Reading @ Power Splitter Output</b>	<b>Sensor B Path Power Splitter Loss</b>
30					
50					
550					
1000					
1244					
1411					
2000					
2512					
2850					
2925					

15. Calculate the desired Sensor B reading for 0 dBm and -39 dBm Test Power Level using the following formula:  $\text{Desired Sensor B reading} = \text{Desired Test Power Level} + C - E$

16. Record the calculated results in Table 3.

Table 3. Level Accuracy with Frequency Test Setting

<b>Freq (MHz)</b>	<b>Desired Sensor B reading for 0 dBm @ Attenuator output</b>	<b>Desired Sensor B reading for -39 dBm @ Attenuator output</b>
30		
550		
1000		
1244		
1411		
2000		
2512		
2850		
2925		

17. Using the power splitter, coaxial cable, adapters and fixed attenuator, connect the Cell Master to the signal source and the power sensor as shown in Figure 2.



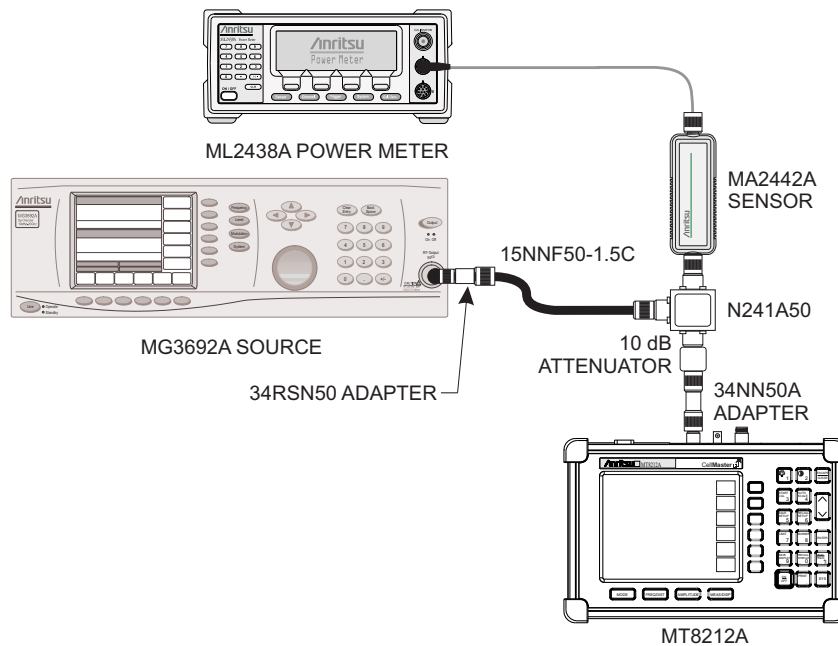

Figure 2. Level Accuracy Test Setup

18. Connect the external power supply (Anritsu part number 40-163) to the Cell Master.
19. On the Cell Master, press and hold the **ESCAPE/CLEAR** key, then press the **ON/OFF** key to turn on the Cell Master. (This sets the instrument to the factory preset state.)
20. On the Cell Master, press the **MODE** key. Use the up/down arrow key to highlight Spectrum Analyzer and press **ENTER** to select spectrum analyzer mode.
21. Press the **MEAS/DISP** key and the Bandwidth soft key.
22. Press the RBW Manual soft key and use the Up/Down arrow key to select 1 kHz. Press **ENTER** to set the resolution bandwidth to 1 kHz.
23. Press the VBW Manual soft key and use the Up/Down arrow key to select 100 Hz. Press **ENTER** to set the video bandwidth to 100 Hz.
24. Press the **FREQ/DIST** key.
25. Press the Span soft key and enter .10, then press the MHz key to set the span to 0.10 MHz.
26. Press the **AMPLITUDE** key.
27. Press the Ref Level soft key, enter 10 and press the **ENTER** key to set the reference level to +10 dBm.
28. Press the **FREQ/DIST** key and the Center soft key.
29. Enter 30 and press the MHz soft key to set the center frequency to 30 MHz.
30. On the Power Meter, press the Sensor key and then the CalFactor soft key. Select the FREQ soft key and enter 30 MHz for the Input Signal Frequency. This sets the power meter to the proper power sensor cal factor. Press the Sensor key to display the power reading.
31. Set the MG3692A output to 30 MHz CW. Adjust the source power level so that the power meter displays the corresponding desired Sensor B reading for 0 dBm (as recorded in Table 3).
32. On the Cell Master, press the **MARKER** key, then the M1 soft key.

33. Select the Marker To Peak soft key to position the marker at the center of the response for the test frequency.
34. Verify that the M1 reading is within the specification stated in Table 4.
35. Repeat steps 29 to 35 for 550 MHz, 1000 MHz, 1244 MHz, 1411 MHz, 2000 MHz, 2512 MHz, and 2925 MHz.
36. Repeat steps 29 to 36 for a power level of -39 dBm.

*NOTE: Change the reference level to -30 dBm.*

Table 4. Level Accuracy with Frequency

Freq (MHz)	@ 0 dBm	@ -39 dBm	Specification
30			±1.5 dB*
550			±1.5 dB*
1000			±1.5 dB*
1244			±1.5 dB*
1411			±1.5 dB*
2000			±1.5 dB*
2512			±1.5 dB
2925			±1.5 dB

\* ±1 dB for units with serial number 405039 and below.

### Level Accuracy with Power Test

c. Equipment Required:

- Anritsu MG3692A Synthesized Signal Source, with options 2A, 4 and 15A
- Anritsu ML2438A Dual Channel Power Meter or equivalent
- Anritsu MA2442A High Accuracy Power Sensor or equivalent (Two each)
- Anritsu N241A50 Power Splitter or equivalent
- Anritsu 34NN50A 50 ohm adapter or equivalent
- Anritsu 34RSN50 50 ohm adapter or equivalent
- Anritsu 34RKNF50 50 ohm adapter or equivalent
- Anritsu 15NNF50-1.5C RF Coaxial Cable or equivalent
- Weinschel 1-10 10 dB Fixed Attenuator
- Weinschel 1-30 30 dB Fixed Attenuator

d. Procedure:

1. Use the recorded values for 50 MHz in Table 2, calculate the desired Sensor B Reading for Test Power Level > -50 dBm at 50 MHz using the following formulas:  
Desired Sensor B Reading = Test Power Level + C - E
2. Record the calculated results in Table 5.

Table 5. Level Accuracy with Power Test Setting

Test Power Level (dBm) @ 50 MHz	Desired Sensor B Reading
+3	
0	
-11	
-13	
-19	
-27	
-32	
-39	
-49	
-51	
-53	
-60	

3. Using the power splitter, coaxial cable, adapters and fixed attenuator, connect the Cell Master to the signal source and the power sensor as shown in Figure 3.
4. On the power meter, press the **Sensor** key and then the **CalFactor** soft key. Select the **FREQ** soft key and enter 50 MHz for the Input Signal Frequency. This sets the power meter to the proper power sensor cal factor. Press the **Sensor** key to display the power reading.
5. Connect the external power supply (Anritsu part number 40-163) to the Cell Master.
6. On the Cell Master, press and hold the **ESCAPE/CLEAR** key, then press the **ON/OFF** key to turn on the Cell Master. (This sets the instrument to the factory preset state.)
7. On the Cell Master, press the **MODE** key. Use the up/down arrow key to highlight Spectrum Analyzer and press **ENTER** to select spectrum analyzer mode.
8. Press the **MEAS/DISP** key and the Bandwidth soft key.
9. Press the RBW Manual soft key and use the Up/Down arrow key to select 1 kHz. Press **ENTER** to set the resolution bandwidth to 1 kHz.
10. Press the VBW Manual soft key and use the Up/Down arrow key to select 100 Hz. Press **ENTER** to set the video bandwidth to 100 Hz.
11. Press the **FREQ/DIST** key.
12. Press the Span soft key and enter .10, then press the MHz soft key to set the span to 0.10 MHz.
13. Press the **AMPLITUDE** key.
14. Press the Ref Level soft key, enter 10 and press the **ENTER** key to set the reference level to +10 dBm.
15. Press the **FREQ/DIST** key and the Center soft key.
16. Enter 50 and press the MHz soft key to set the center frequency to 50 MHz.
17. Set the MG3692A output to 50 MHz CW. Adjust the source power so that the power meter displays the corresponding desired Sensor B Reading for +3 dBm (as recorded in Table 5).
18. Press the **MARKER** key, then the M1 soft key.

19. Select the Marker To Peak soft key to position the marker at the center of the response for the test frequency.
20. Verify that the M1 reading is within the specification from the input signal as shown in Table 7.
21. Repeat steps 15 through 20 for input levels of 0 dBm, -11 dBm, -13 dBm, -19 dBm, -27 dBm, -32 dBm, -39 dBm and -49 dBm.

*NOTE: Change the reference level as indicated in Table 7 for the corresponding test power level.*

22. Disconnect the power splitter and attenuator from the Cell Master.
23. Set the MG3692A output power level to 5 dBm.
24. Connect sensor A to the MG3692A output, measure the output power level and record the value in column A of Table 6.

Table 6. Output Power Level

	<b>A</b>	<b>B</b>	<b>C</b>	<b>D</b>	<b>E</b>
<b>Freq (MHz)</b>	<b>Sensor A Reading @ Source Output</b>	<b>Sensor A Reading @ End of Attenuator</b>	<b>Splitter/Attenuator Combined Loss</b>	<b>Sensor B Reading @ Pwr Splitter Output</b>	<b>Sensor B Path Power Splitter Loss</b>
50					

25. Disconnect sensor A from the MG3692A output.
26. Connect the power splitter to the MG3692A output and connect Sensor B to one of the power splitter outputs. Install the 30 dB fixed attenuator to the other power splitter output, and connect Sensor A to the attenuator. Refer to Figure 1.
27. Record the new sensor A reading in column B of Table 6.
28. Record the Sensor B reading in column D of Table 6.
29. Calculate the Splitter/Attenuator Combined Loss using the following formula and record the result in column C of Table 6:  $C = A - B$
30. Calculate the Sensor B path Power Splitter Loss using the following formula and record the result in column E of Table 6:  $E = A - D$
31. Calculate the desired Sensor B Reading for Test Power Level  $< -50$  dBm using the following formulas:  $\text{Desired Sensor B Reading} = \text{Test Power Level} + C - E$
32. Record the calculated results in Table 6.
33. Using the power splitter, coaxial cable, adapters and 30 dB fixed attenuator, connect the Cell Master to the signal source and the power sensor as shown in Figure 3.
34. Adjust the MG3692A output power level so that the power meter displays the corresponding desired Sensor B reading for -51 dBm (as recorded in Table 6).
35. Press the **MARKER** key, then the M1 soft key.
36. Select the Marker To Peak soft key to position the marker at the center of the response for the test frequency.
37. Verify that the M1 reading is within the specification from the input signal as shown in Table 7.
38. Repeat steps 34 to 37 for Test Power Levels of -53 dBm and -60 dBm.

*NOTE: Change the reference level as indicated in Table 7 for the corresponding test power level.*

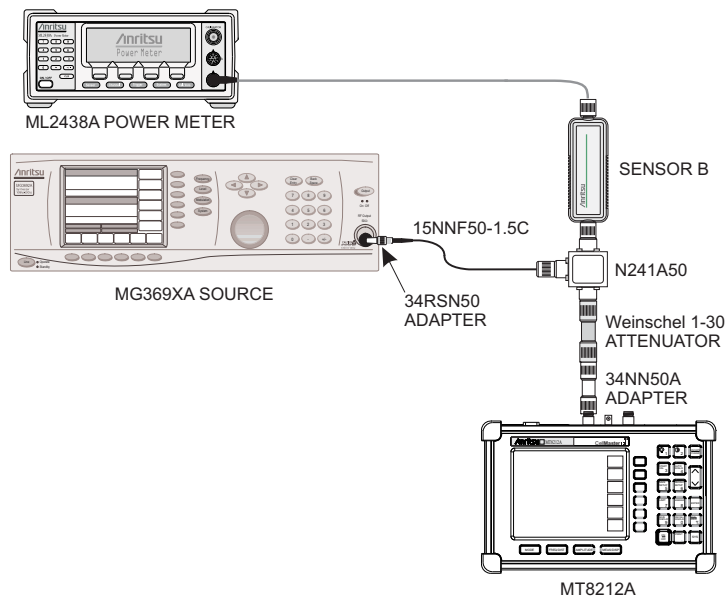

Figure 3. Level Accuracy Setup, 30 dB Attenuator

Table 7. Level Accuracy with Power

Input Power Level (dBm)	Reference Level (dBm)	Specification * (dB)	Marker Reading (dBm)
+3	+10	±1.5	
0	+10	±1.5	
-11	-10	±1.5	
-13	-10	±1.5	
-19	-10	±1.5	
-27	-20	±1.5	
-32	-30	±1.5	
-39	-30	±1.5	
-49	-40	±1.5	
-51	-40	±1.5	
-53	-50	±1.5	
-60	-50	±1.5	

\* ±1 dB for units with serial number 405039 and below.

## 11. Power Meter Verification (Option 29)

The following test can be used to verify the accuracy of the power measurements.

a. Equipment Required:

- Anritsu MG3692A Synthesized Signal Source, with options 2A, 4 and 15A
- Anritsu ML2438A Dual Channel Power Meter or equivalent
- Anritsu MA2442A High Accuracy Power Sensor or equivalent
- Anritsu N241A50 Power Splitter or equivalent
- Anritsu 34NN50A 50Ω adapter or equivalent
- Anritsu 34RSN50 50Ω adapter or equivalent
- Anritsu 34RKNF50 50Ω adapter or equivalent
- Anritsu 15NNF50-1.5C RF Coaxial Cable or equivalent
- Weinschel 1-10 10 dB Fixed Attenuator

b. Procedure:

1. Turn on the power meter and signal source.

*NOTE: Before continuing, allow a 30-minute warm up for the internal circuitry to stabilize.*

2. On the power meter, press the Channel key, the Setup soft key and then the CHANNEL soft key to display Channel 2 setup menu. Press the INPUT key twice to set the input configuration to B. Press the Sensor key to display both Sensor A and Sensor B Readings.
3. Connect the power sensors to the power meter and calibrate the sensors.
4. Set the MG3692A output power level to 5 dBm.
5. Set the MG3692A output to 50 MHz CW.
6. On the power meter, press the Sensor key, the Cal Factor soft key, and then the FREQ soft key. Use the keypad to enter 50 MHz as the input signal frequency, which sets the power meter to the proper power sensor cal factor. Press the SENSOR key on the power meter to display the power reading.
7. Connect sensor A to the MG3692A output, measure the output power level and record the value in column A of Table 8.

Table 8. Output Power Level

	A	B	C	D	E
Freq (MHz)	Sensor A Reading @ Source Output	Sensor A Reading @ end of Attenuator	Splitter/Attenuator Combined Loss	Sensor B Reading @ Power Splitter Output	Sensor B Path Power Splitter Loss
50					
1000					
2000					
2850					

8. Disconnect Sensor A from the MG3692A output.
9. Connect the power splitter to the MG3692A output and the Sensor B to one of the power splitter outputs. Install the 10 dB Fixed Attenuator to the other power splitter output and then connect Sensor A to the end of the Attenuator. Refer to Figure 1.
10. Record the new sensor A reading in column B of Table 8.
11. Record Sensor B reading in column D of Table 8.
12. Calculate the Splitter/Attenuator Combined Loss using the following formula and record the result in column C of Table 8:  $C = A - B$
13. Calculate the Sensor B path Power Splitter Loss using the following formula and record the result in column E of Table 8:  $E = A - D$
14. On the power meter, press the INPUT soft key seven times and then press the System key to display the sensor A reading.
15. Repeat steps 4 through 11 for 1000 MHz, 2000 MHz and 2850 MHz.
16. Calculate the desired Sensor B Reading for  $-30$  dBm Test Power Level at the end of 10 dB attenuator using the following formula:  $\text{Desired Sensor B Reading} = \text{Test Power Level} + C - E$
17. Record the calculated results in Table 9.

Table 9.  $-30$  dBm Test Power Level

Freq (MHz)	Desired Sensor B Reading for $-30$ dBm Input to Cell Master
50	
1000	
2000	
2850	

18. Using the power splitter, coaxial cable and adapters, connect the Cell Master to the signal source and the power sensor as shown in Figure 4.

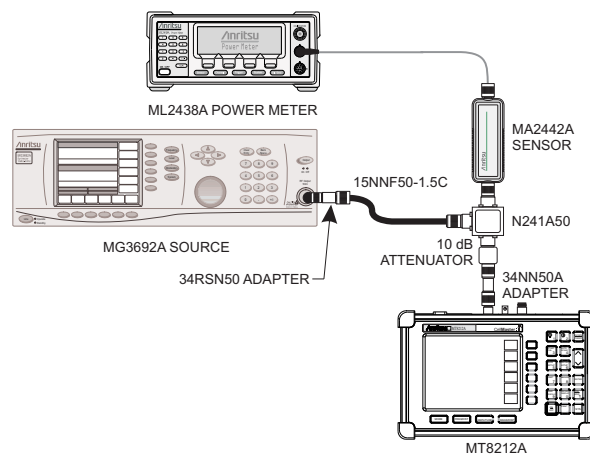

Figure 4. Power Meter Verification Setup

19. Connect the external power supply (Anritsu part number 40-163) to the Cell Master.
20. On the Cell Master, press and hold the **ESCAPE/CLEAR** key, then press the **ON/OFF** key to turn on the Cell Master. (This sets the instrument to the factory preset state.)
21. Press the **MODE** key. Use the Up/Down arrow key to highlight Power Meter and then press **ENTER**.
22. Press the Center soft key and enter 50, then press the MHz soft key to set the center frequency to 50 MHz.
23. Press the Span soft key and enter 3, then press the MHz key to set the span to 3 MHz.
24. On the Power Meter, press the Sensor key and then the CalFactor soft key. Select the **FREQ** soft key and enter 50 MHz for the Input Signal Frequency. This sets the power meter to the proper power sensor cal factor. Press the Sensor key to display the power reading.
25. Set the MG3692A output to 50 MHz CW and adjust the power level so that the power meter displays the corresponding desired Sensor B Reading for -30 dBm as recorded in Table 9.
26. Verify that the Power Meter reading is within the specifications in Table 10.

*NOTE: If the reading is unstable, turn on RMS Averaging by pressing the MEAS/DISP key, then the RMS Averaging soft key. The number of points to average can be set to low, medium or high.*

Table 10. Output Power Level

Freq (MHz)	Measured Value	Specification
50		-30 dBm ± 1.5 dB*
1000		-30 dBm ± 1.5 dB*
2000		-30 dBm ± 1.5 dB*
2850		-30 dBm ± 1.5 dB

\* -30 dBm ±1.0 dB for units with serial number 405039 and below.

27. Repeat steps 22 and 26 for 1000 MHz, 2000 MHz, and 2850 MHz.



## 12. T1/E1 Verification

This procedure verify that the T1/E1 Tester of the Cell Master is functioning properly.

### a. Equipment Required:

- Tektronix TDS3032B Oscilloscope with option TDS 3TMT
- Tektronix AFTDS Differential Signal Adapter
- Anritsu Bantam-Plug-to-Bantam-Plug Extender Cable (P/N 806-16)

### T1/E1 Self Test

1. Press and hold the **ESCAPE/CLEAR** key, then press the **ON/OFF** key to turn on the Cell Master. (This sets the instrument to the factory preset state.)

*NOTE: Before continuing, allow a 30-minute warm up for the internal circuitry to stabilize.*

2. Press the **SYS** key, then the Self Test soft key.
3. When the Cell Master has passed the standard self test, press the T1/E1 Test soft key.
4. After the Cell Master has passed the T1/E1 self test, press the **ESCAPE/CLEAR** key.

### T1 Mask Test

1. Set the Adapter switch to 100 ohms, then connect it to the scope.
2. Connect the Adapter cable to the Transmit port of the Cell Master.
3. On the Cell Master, press the **MODE** key, then use Up/Down key to highlight T1 Tester and press the **ENTER** key.
4. Press the **MEAS/DISP** key and the Vpp soft key, and use the Terminate/Bridged soft key to select Terminate at the bottom of the display.
5. Press the Back soft key, then press the BERT soft key and select the Setup BERT soft key.
6. Press the More soft key, then select the Clock Source soft key.
7. Press the Internal soft key, then press the Back soft key.
8. Press the Transmit Level soft key and select 0 dB, then press the Back soft key twice.
9. Press the Pattern soft key, then use the Up/Down arrow key to highlight 1 IN 8 and press the **ENTER** key.
10. Set up the scope as follows:
  - (a) Press the QUICKMENU key, then use the MENU soft key to select Telecom.
  - (b) Use the Standard arrow soft key to select G.703DS1 (ITU-T), 1.544 M b/s.
  - (c) Press the AUTOSET key.
  - (d) Press the Waveform Threshold soft key, and use the Control/Coarse knob to set the the waveform to 400 and the Threshold to 20.
  - (e) Press the Autofit soft key and use the control/Coarse knob to set the number to 1.
  - (f) Press the Run soft key.
11. Record the failed number for three sweeps. The failed number should be less than the selected Threshold, which is 20.

### E1 Mask Test

1. Set the Adapter switch to 120 ohms and connect it to the scope.
2. Connect the Adapter cable to the Transmit port of the Cell Master.

3. Press and hold the **ESCAPE/CLEAR** key, then press the **ON/OFF** key to turn on the Cell Master. (This sets the instrument to the factory preset state.)

*NOTE: Before continuing, allow a 30-minute warm up for the internal circuitry to stabilize.*

4. On the Cell Master, press the **MODE** key, then use Up/Down key to highlight E1 Tester and press the **ENTER** key.
5. Press the **MEAS/DISP** key and the Vpp soft key, and use the Terminate/Bridged soft key to select Terminate at the bottom of the display.
6. Press the Back soft key, then press the BERT soft key and select the Setup BERT soft key.
7. Press the More soft key, then press the Impedance soft key and select 120Ω.
8. Press the Back soft key, then select the Clock Source soft key.
9. Press the Internal soft key, then press the Back soft key.
10. Press the Pattern soft key, then use the Up/Down arrow key to highlight 1 IN 8 and press the **ENTER** key.
11. Set up the scope as follows:
  - (a) Press the QUICKMENU key, then use the MENU soft key to select Telecom.
  - (b) Use the Standard arrow soft key to select E1 Sym (ITU-T), 2.048 M b/s.
  - (c) Press the AUTOSET key.
  - (d) Press the Waveform Threshold soft key, and use the Control/Coarse knob to set the the waveform to 400 and the Threshold to 20.
  - (e) Press the Run soft key.
12. Record the failed number for three sweeps. The failed number should be less than the selected Threshold, which is 20.

#### T1 Transmit Level Test

1. Set the Adapter switch to 100 ohms then connect it to the scope.
2. Connect the Adapter cable to the Transmit port of the Cell Master.
3. Press and hold the **ESCAPE/CLEAR** key, then press the **ON/OFF** key to turn on the Cell Master. (This sets the instrument to the factory preset state.)

*NOTE: Before continuing, allow a 30-minute warm up for the internal circuitry to stabilize.*

4. On the Cell Master, press the **MODE** key, then use Up/Down key to highlight T1 Tester and press the **ENTER** key.
5. Press the **MEAS/DISP** key and the Vpp soft key, and use the Terminate/Bridged soft key to select Terminate at the bottom of the display.
6. Press the Back soft key, then press the BERT soft key and select the Setup BERT soft key.
7. Press the More soft key, then select the Clock Source soft key.
8. Press the Internal soft key, then press the Back soft key.
9. Press the Transmit Level soft key and select 0 dB, then press the Back soft key twice.
10. Press the Pattern soft key, then use the Up/Down arrow key to highlight 1 IN 8 and press the **ENTER** key.
11. Set up the oscilloscope as follows:
  - (a) Press QUICK MENU, then use the MENU soft key to select Telecom.
  - (b) Use the Standard arrow soft key to select None.

- (c) Use the MENU soft key again to select Scope.
- (d) Press the AUTOSET key, then set the horizontal SCALE to 2 micro seconds.
- (e) Press the MEASURE key, then press the MORE soft key three times.
- (f) Select the Pk-Pk soft key and record the Pk-Pk reading. The specification is 6.0 to 7.6 Vp-p.

#### E1 Transmit Level Test

1. Set the probe switch to 120 ohms.
2. Press and hold the **ESCAPE/CLEAR** key, then press the **ON/OFF** key to turn on the Cell Master. (This sets the instrument to the factory preset state.)

*NOTE: Before continuing, allow a 30-minute warm up for the internal circuitry to stabilize.*

3. On the Cell Master, press the **MODE** key, then use Up/Down key to highlight E1 Tester and press the **ENTER** key.
4. Press the **MEAS/DISP** key and the Vpp soft key, and use the Terminate/Bridged soft key to select Terminate at the bottom of the display.
5. Press the Back soft key, then press the BERT soft key and select the Setup BERT soft key.
6. Press the More soft key, then select the Clock Source soft key.
7. Press the Internal soft key, then press the Back soft key.
8. Press the Impedance soft key and select 120Ω, then press the Back soft key twice.
9. Press the Pattern soft key, then use the Up/Down arrow key to highlight 1 IN 8 and press the **ENTER** key.
10. Set up the Oscilloscope as follows:
  - (a) Press QUICK MENU, then use the MENU soft key to select Telecom.
  - (b) Use the Standard arrow soft key to select None.
  - (c) Use the MENU soft key again to select Scope.
  - (d) Press the AUTOSET key, then set the horizontal SCALE to 1 micro second.
  - (e) Press the MEASURE key, then press the MORE soft key three times.
  - (f) Select the Pk-Pk soft key and record the Pk-Pk reading. The specification is 4.2 to 7.2 Vp-p.

#### T1 Error Detection Verification

*NOTE: During this test the both transmit and Receive cable should be disconnected.*

1. Press and hold the **ESCAPE/CLEAR** key, then press the **ON/OFF** key to turn on the Cell Master. (This sets the instrument to the factory preset state.)
2. On the Cell Master, press the **MODE** key, then use Up/Down key to highlight T1 Tester and press the **ENTER** key.
3. Press the **MEAS/DISP** key and the Vpp soft key, and use the Terminate/Bridged soft key to select Terminate at the bottom of the display.
4. Press the Back soft key, then press the BERT soft key and select the Setup BERT soft key.
5. Press the More soft key, then select the Clock Source soft key.
6. Press the Internal soft key, then press the Back soft key.
7. Press the Setup Error Insert soft key, then select the Bit soft key. Enter a number (for example, 150) and press **ENTER**.
8. Press the Back soft key, then select the Transmit Level soft key and select 0 dB.
9. Press the Back soft key three times.

10. Press the Measure BERT soft key and select the Start/Stop Measure soft key.
11. Press the Insert Errors soft key and observe the number in the Bit Errors row. The number must match the number entered in Step 7 above. This number must increase by the number entered in Step 7 above every time the Insert Errors soft key is pressed. For example, if 150 is entered in Step 7, the first number observed will be 150. The next time the Insert Errors soft key is pressed, the number must be 300, etc.

#### E1 Error Detection Verification

*NOTE: Disconnect all the cables from the Transmit and Receive ports during this test.*

1. Press and hold the **ESCAPE/CLEAR** key, then press the **ON/OFF** key to turn on the Cell Master. (This sets the instrument to the factory preset state.)
2. On the Cell Master, press the **MODE** key, then use Up/Down key to highlight E1 Tester and press the **ENTER** key.
3. Press the **MEAS/DISP** key and the Vpp soft key, and use the Terminate/Bridged soft key to select Terminate at the bottom of the display.
4. Press the Back soft key, then press the BERT soft key and select the Setup BERT soft key.
5. Press the More soft key, then select the Clock Source soft key.
6. Press the Internal soft key, then press the Back soft key.
7. Press the Impedance soft key and select 120 $\Omega$ , then press the Back soft key twice.
8. Press the Setup Error Insert soft key, then select the Bit soft key. Enter a number (for example, 150) and press **ENTER**.
9. Press the Back soft key three times.
10. Press the Measure BERT soft key and select the Start/Stop Measure soft key.
11. Press the Insert Errors soft key and observe the number in the Bit Errors row. The number must match the number entered in Step 8 above. This number must increase by the number entered in Step 8 above every time the Insert Errors soft key is pressed. For example, if 150 is entered in Step 8, the first number observed will be 150. The next time the Insert Errors soft key is pressed, the number must be 300, etc.

### 13. Termination Verification

This test verifies the accuracy of the Cell Master SM/PL termination using the precision return loss mode of the 541XXA Scalar Measurement System. Measurements of terminations using this mode provide results that are traceable to the NIST (National Institute of Standards and Technology) standards for the precision airline.

a. Equipment Required:

- Scalar Measurement System, Anritsu 541XXA
- Offset SWR Autotester, Anritsu 560-97A50-20
- Precision Airline, Anritsu 18NF50
- Open/Short, Anritsu 22N50
- 50 Ohm Termination, Anritsu 28N50-2
- Source Adapter, Anritsu 34NN50A

b. Procedure

1. Connect the test equipment as shown in Figure 5.

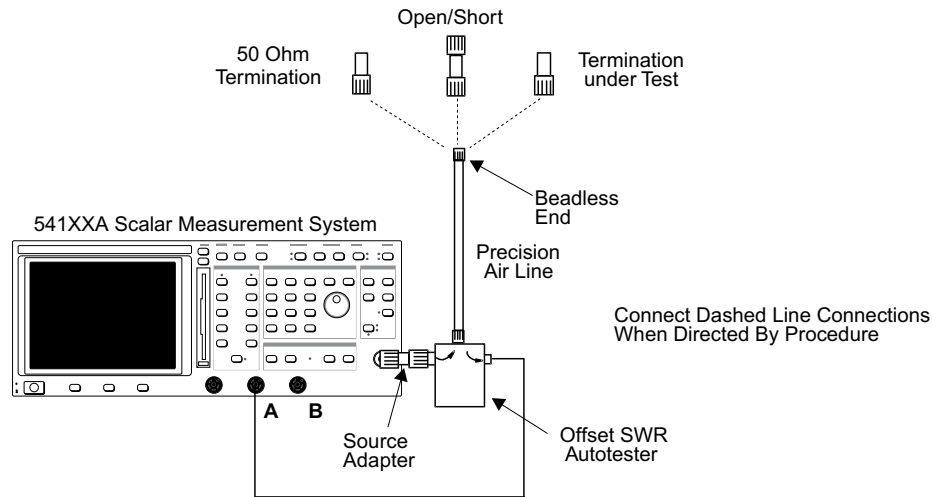

Figure 5. 541XXA Precision Return Loss Setup

2. Press the Power key on the 541XXA to On.
3. Press the System Menu key.
4. Using the Menu up-down keys: Highlight RESET, then press the Select key.
5. At the RESET MENU display, use the Menu up-down keys to highlight RESET TO FACTORY DEFAULTS, then press the Select key.
6. Set the signal source for the frequency range as follows:
  - (a) Press the Frequency key.
  - (b) Using the Data Entry Keypad or Data Entry Knob, set the Start frequency to 0.01 GHz. Press the Enter key.
  - (c) Using the Data Entry Keypad or Data Entry Knob, set the Stop frequency to 4.0 GHz. Press the Enter key.
7. Press the Channel 2 Display On/Off key to Off.
8. Press the Channel 1 Menu key.

9. Using the Menu up-down keys: Highlight PRECISION RL, then press the Select key.
10. At the PRECISION RETURN LOSS menu display, use the Menu up-down keys to highlight FINAL, then press the Select key.
11. Press the Calibration key.
12. At the CALIBRATION menu display, use the Menu up-down keys to highlight START CAL, then press the Select key.
13. At the PRECISION RETURN LOSS CALIBRATION menu display prompt, connect the Offset SWR Autotester to Input A, if you have not done so yet.
14. Connect the precision air line to the Offset SWR Autotester test port. Position the air line pointing vertically upward. Downward or horizontal positions make connector pin alignment difficult.

*NOTE: Ensure that the bead-less end of the precision airline is at the measurement connection point.*

15. Press the Select key when ready.
16. At the PRECISION RETURN LOSS CALIBRATION menu prompt, connect the Open to the bead-less end of the airline. Press the Select key to start the calibration.
17. Verify that the display resembles that shown in Figure 6.

**CAUTION**

*During both calibration and measurement, be sure to properly align the bead-less connector of the air-line. When the connectors are mis-aligned, a spike will usually be visible on the display.*

18. At the next menu prompt, remove the Open and connect the Short to the bead-less end of the air-line. Press the Select key to start the calibration process.
19. At the next menu prompt, remove the Short and connect the 50 Ohm Termination to the bead-less end of the air line. Press the Select key to start the calibration process.
20. When the calibration is complete, remove the 50 Ohm Termination.

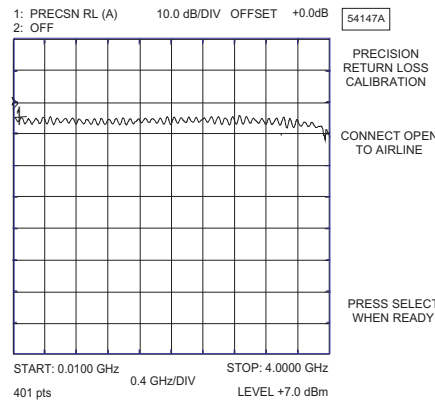

Figure 6. Example of a Good Connection

21. Connect the SM/PL termination to the bead-less end of the air line and press the Select key to begin the measurement.
22. Observe that the waveform displayed resembles that shown in Figure 7.
23. Press the Cursor On/Off key to On.

24. Observe the Cursor menu readout. The minimum return loss reading for the SM/PL termination should be 42 dB (the instrument readout is -42 dB).

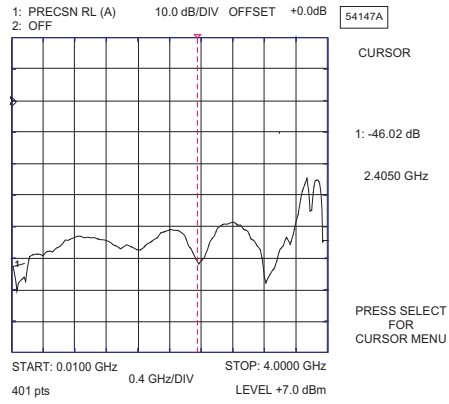

Figure 7. Direct Readout of the Precision Return Loss

## 14. InstaCal Module Verification

This test verifies the performance of the Anritsu Cell Master InstaCal Calibration Module. The InstaCal Module, part number ICN50, is an optional accessory for the MT8212A.

a. Equipment Required:

- InstaCal Module, part number ICN50
- 20 dB offset, Anritsu SC5270
- 6 dB offset, Anritsu SC5237

b. Procedure

1. Press and hold the **ESCAPE/CLEAR** key, then press the **ON/OFF** key to turn on the Cell Master. (This sets the instrument to the factory preset state.)

*NOTE: Before continuing, allow a five minute warm up for the internal circuitry to stabilize.*

2. Press the MODE soft key.
3. Use the Up/Down arrow key to highlight RETURN LOSS, then press **ENTER**.
4. Press the **START CAL** key. The message “CONNECT OPEN or InstaCal TO RF Out PORT” will appear in the display.
5. Connect the InstaCal module to the RF Out port and press the **ENTER** key.

*NOTES: If this particular InstaCal module has been used to calibrate this Cell Master before, the Cell Master senses the familiar InstaCal module and automatically calibrates the unit using the OSL procedure.*

*If the Cell Master senses that the characterization data for the InstaCal module connected to this Cell Master is different than the one currently stored, it will display soft key options to keep or replace the InstaCal characterization data.*

*Selecting the YES soft key transfers all of the characterization data from this InstaCal module to the Cell Master. The transfer may take up to three minutes. This option is preferred if this InstaCal module is to stay with this particular Cell Master. Once completed, the data will not need to be transferred again for this combination of Cell Master and InstaCal module.*

*Selecting the NO soft key will temporarily transfer only the portion of the characterization data necessary for this particular calibration. This transfer takes approximately 30 to 60 seconds, and will have to be repeated every time a calibration is done using this combination of Cell Master and InstaCal module.*

6. Verify that the calibration has been properly performed by checking that the CAL ON! message is displayed in the upper left corner of the display.
7. Remove the InstaCal module from the RF Out port and connect the 20 dB Offset to the RF Out port.
8. Measure the return loss of the 20 dB Offset. The level should be 20 dB,  $\pm 2$  dB across the calibrated frequency range.
9. Remove the 20 dB Offset from the RF Out port and connect the 6 dB Offset to the RF Out port.
10. Measure the return loss of the 6 dB Offset. The level should be 6 dB,  $\pm 1.2$  dB across the calibrated frequency range.



## 15. Battery Pack Removal and Replacement

This procedure provides instructions for removing and replacing the Cell Master battery pack.

*NOTE: Many of the procedures in this section are generic, and apply to many similar instruments. Photos and illustrations used are representative and may show instruments other than the Cell Master.*

1. With the Cell Master standing upright on a stable surface, locate the battery access door (Figure 8).

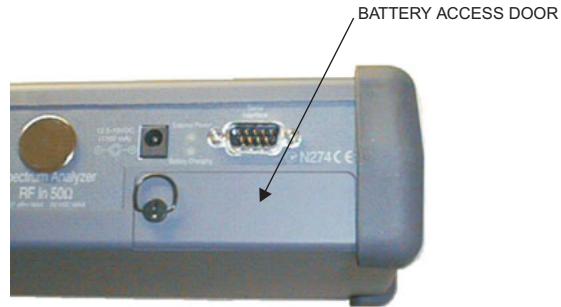

Figure 8. Battery Access Door Location

2. Lift up the access door handle and rotate it 90 degrees counterclockwise, as illustrated in Figure 9.



Figure 9. Rotate the Battery Access Door Handle

3. Lift the door and remove, as illustrated in Figure 11.

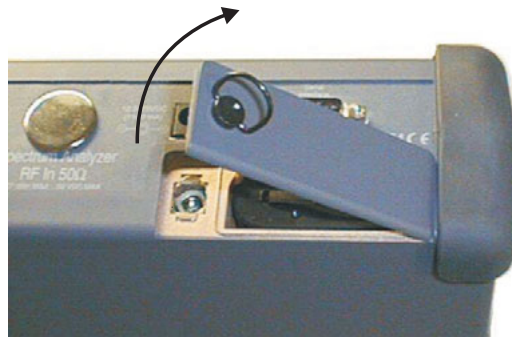

Figure 10. Removing the Battery Access Door

4. Grasp the battery lanyard and pull the battery straight up and out of the unit, as illustrated in Figure 12.

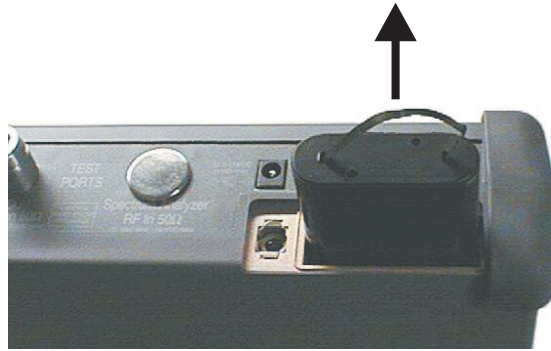

Figure 11. Removing the Battery

5. Replacement is the opposite of removal. Note the orientation of the battery contacts, and be sure to insert the new battery with the contacts facing the rear of the unit (Figure 13).

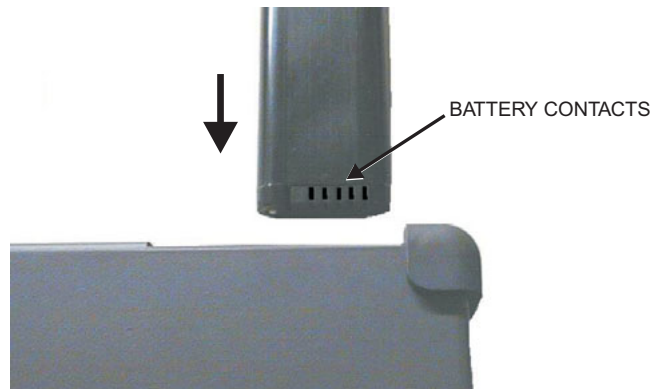

Figure 12. Battery Orientation

## 16. Battery Information

The following information relates to the care and handling of the Cell Master battery, and NiMH batteries in general.

- The Nickel Metal Hydride (NiMH) battery supplied with the Cell Master is shipped in a discharged state. Before using the Cell Master, the internal battery must first be charged for three hours, either in the Cell Master or in the optional battery charger (Anritsu part number: 2000-1029).
- Use only Anritsu approved battery packs.
- Recharge the battery only in the Cell Master or in an Anritsu approved charger.
- With a new NiMH battery, full performance is achieved after three to five complete charge and discharge cycles.
- When the Cell Master or the charger is not in use, disconnect it from the power source.
- Do not charge batteries for longer than 24 hours; overcharging may shorten battery life.
- If left unused a fully charged battery will discharge itself over time.
- Temperature extremes will affect the ability of the battery to charge; allow the battery to cool down or warm up as necessary before use or charging.
- Discharge an NiMH battery from time to time to improve battery performance and battery life.

- The battery can be charged and discharged hundreds of times, but it will eventually wear out.
- The battery may need to be replaced when the operating time between charging becomes noticeably shorter than normal.
- Never use a damaged or worn out charger or battery.
- Storing the battery in extreme hot or cold places will reduce the capacity and lifetime of the battery.
- Never short-circuit the battery terminals.
- Do not drop, mutilate or attempt to disassemble the battery.
- Do not dispose of batteries in a fire!
- Batteries must be recycled or disposed of properly. Do not place batteries in household garbage.
- Always use the battery for its intended purpose only.

#### 16.1. Battery Testing Procedure

1. With the Cell Master off and the battery installed, connect the Universal AC Adapter to the 12.5-15VDC (1350 mA) connector. The External Power LED and the Battery Charging LED will light.

*NOTES: If the Battery Charging LED does not light, the battery may be too low to immediately start full charging. Leaving the unit connected to AC power for several hours may bring the battery up to a level where full charging can begin. Turn the unit off and back on to see if the Battery Charging LED lights indicating a full charge cycle has begun. Charging is inhibited below 0°C and above 45°C. If the unit is too hot, the battery will not start charging until the unit temperature has reached 43°C.*

2. Disconnect the AC-DC Adapter when the Battery Charging LED turns off, indicating the battery is fully charged.
3. Press and hold the **ESCAPE/CLEAR** key, then press the **ON/OFF** key to turn on the Cell Master. This sets the instrument to the factory preset state. Press **ENTER** when prompted to continue.
4. Press the **SYS** key, followed by the STATUS soft key. Verify that the indicated battery charge is  $\geq$  80%. If the value is 80% or above, press the **ESCAPE/CLEAR** key and continue with this procedure.  
If the value is lower than 80%, a discharge/charge cycle may be needed to improve the battery capacity. Completely discharge the battery, as described in Steps 5 and 6 below, and then recharge the battery as described in Steps 1 and 2. If the battery capacity does not increase after a discharge/charge cycle, replace the battery.
5. Press the **START CAL** key (to keep the Cell Master from going into HOLD mode) and make note of the test start time.
6. When the Cell Master display fades and the Cell Master switches itself off, make note of the test stop time.
7. The total test time (Step 5 to Step 6) should be  $\geq$  1.5 hours. If the battery charge is near 80% and the total battery test time is <70 minutes, replace the battery.

## 17. Front Panel Assembly Removal and Replacement

This procedure provides instructions for removing and replacing the Cell Master front panel assembly. With the front panel assembly removed, the LCD display, keypad PCB, keypad membrane, and main PCB assemblies can be removed and replaced.

*NOTE: Many of the procedures in this section are generic, and apply to many similar instruments. Photos and illustrations used are representative and may show instruments other than the Cell Master.*

1. Place the Cell Master face up on a stable work surface.
2. Remove the four rubber corner bumpers by carefully lifting and sliding the bumpers off of the case corners (Figure 13).



Figure 13. Removing the Corner Bumpers

3. With the bumpers removed, the access holes for the case screws are revealed. Use a Phillips screwdriver to remove the four screws securing the two halves of the Cell Master case together.
4. Carefully lift up on the right side (as viewed from the front) of the front half of the case and begin to separate the two halves.

### CAUTION

*Do not force or pull the two halves of the case apart completely, as there are delicate cables attached between the two halves that must be disconnected first.*

5. Carefully depress the latch tab and disconnect the LCD display cable from J3 on the main PCB.
6. Carefully disconnect the keypad interface cable from J4 on the main PCB.

7. Carefully disconnect the LCD display backlight cable from J1 on the main PCB.

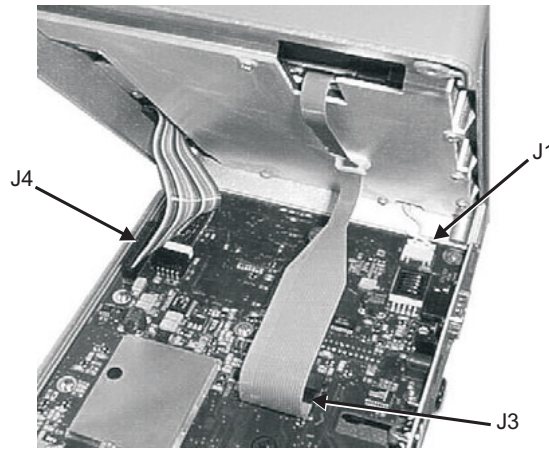

Figure 14. Cell Master Front Panel Cable Connections

8. Remove the front panel assembly.
9. Reverse the above steps to replace the front panel assembly.

*NOTE: The corner bumpers only mount one way. That is, the raised area inside one end of the bumper (Figure 15) is made to conform to the contour of the front cover only.*



Figure 15. Corner Bumper Detail

## 18. LCD Assembly Replacement

This procedure provides instructions for removing and replacing the Liquid Crystal Display (LCD) once the front panel assembly has been separated from the Cell Master.

1. Remove the front panel assembly as directed in section 17.
2. Place the front panel assembly face down on a protected work surface.
3. Remove the 14 Phillips screws that attach the backing plate to the front panel assembly.

4. Release the LCD display cable from the retaining clip on the front panel backing plate.

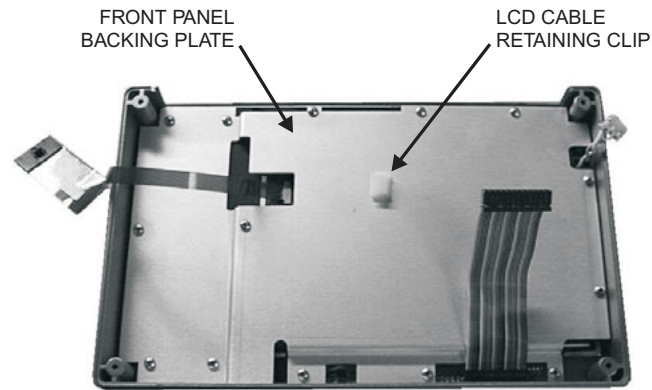

Figure 16. Front Panel Backing Plate

5. Remove the front panel backing plate, carefully feeding the LCD cable through the access hole to avoid damage to the cable or connector.
6. Remove the rubber cushion pad from the LCD assembly and remove the assembly.
7. Reverse the above steps to install the replacement assembly.

## 19. Key Pad PCB Replacement

This procedure provides instructions for removing and replacing the key pad PCB.

1. Remove the front panel assembly as directed in section 17.
2. Place the front panel assembly face down on a protected work surface.
3. Remove the 14 Phillips screws that attach the backing plate to the front panel assembly.
4. Release the LCD display cable from the retaining clip on the front panel backing plate (Figure 16).
5. Remove the front panel backing plate, carefully feeding the LCD cable through the access hole to avoid damage to the cable or connector.
6. Remove the rubber cushion pad from the key pad PCB and remove the PCB.

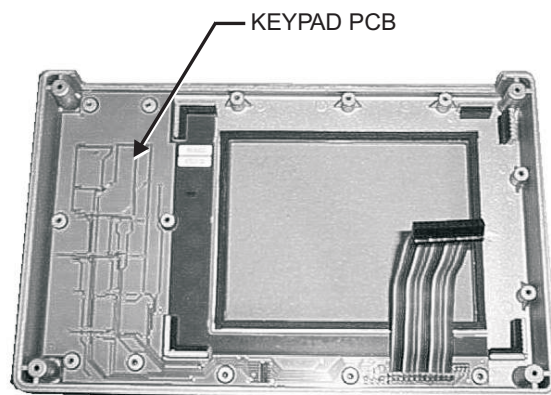

Figure 17. Front Panel Keypad PCB Location

7. Reverse the above steps to install the replacement assembly.

## 20. Key Pad Membrane Replacement

This procedure provides instructions for replacing the key pad membrane.

1. Remove the front panel assembly as directed in section 17.
2. Remove the key pad PCB as directed in section 19.
3. Remove the keypad membrane by gently pulling the membrane up and out of the holes in the front panel.

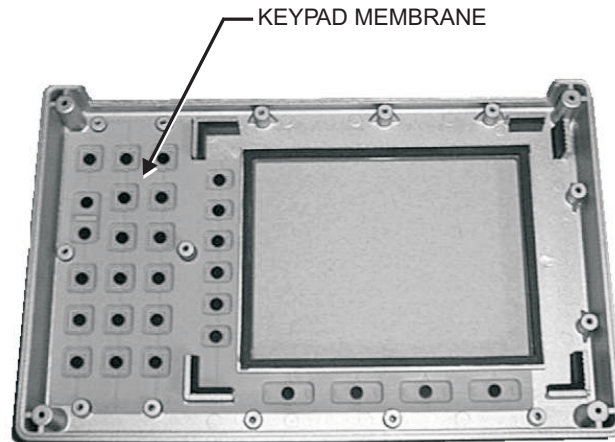

Figure 18. Front Panel Keypad Membrane

4. Reverse the above steps to install the replacement membrane.

## 21. Main PCB Assembly Replacement

This procedure provides instructions for replacing the main PCB assembly with the connector panel attached.

1. Remove the front panel assembly as directed in section 17.
2. Disconnect the battery connector from J7 on the main PCB.
3. Disconnect the semi-rigid coaxial cable from the RF In connector on the connector panel.

4. Remove the three PCB mounting screws and lift the Control PCB assembly with the connector panel attached slightly.

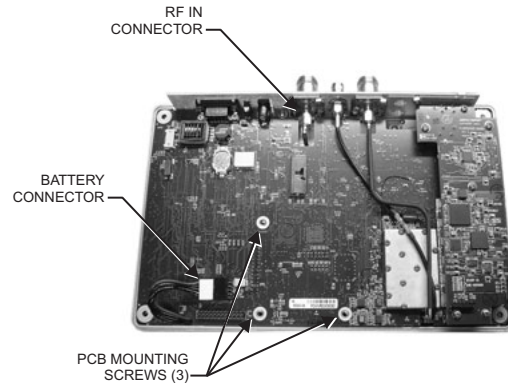

Figure 19. Main PCB (shown with optional T1/E1 PCB installed)

5. Carefully reach between the Main PCB and the SPA PCB and disconnect the cables from J2 and J4 on the SPA PCB.

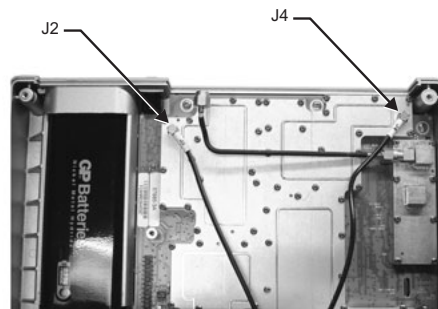

Figure 20. Spectrum Analyzer PCB

6. Remove the Main PCB.
7. Remove the three .25" standoffs and four Phillips screws and remove the Spectrum Analyzer PCB.
8. Reverse the above steps to install the new main PCB.

*NOTE: The main PCB connector panel fits into grooves in the two halves of the case. Make sure the panel is correctly aligned with the grooves before reassembling the two halves together.*



## 22. Accessories and Replaceable Parts

Accessories and replaceable parts for the Cell Master MT8212A are listed below.

### Accessories

Part Number	Description	Qty
10580-00083	User's Guide, Cell Master MT8212A	1
10580-00094	Programming Manual, Cell Master MT8212A (disk only)	1
2300-347	Handheld Software Tools	1
40-163	Power Supply	1
2000-1029	Battery Charger	1
22N50	Open/Short, N Male	1
SM/PL	Precision Termination, N Male	1
806-62	Automotive Power Adapter	1
806-16	Bantam Plug to Bantam Plug Cable Assembly	1
806-116	Bantam Plug to BNC Male Cable Assembly, 8 ft	1
806-117	Two Bantam Plugs to RJ48 Cable Assembly, 8 ft	1
800-441	Serial Interface Cable Assembly	1
48258	Soft Carrying Case	1

### Replaceable Parts

Part Number	Description	Qty
510-87	N Male Connector	2
15-102	Liquid Crystal Display Assembly	1
633-27	Rechargeable Battery, NiMH	1
ND60694	Main/SPA PCB Assembly, MT8212A (serial number 409999 and below)	1
ND63024	Main/SPA PCB Assembly, MT8212A (serial number 410000 and above)	1
52737-3	Keypad PCB Assembly	1
46649-4	Membrane Keypad, Main	1

### Hardware

Part Number	Description	Qty
900-861	Pan Head Screw, 4-20, 0.365	18
900-791	Screw, 2-56, 0.375	77
900-720	Screw, 4-40, 0.187	5
900-326	Kep Nut, 4-40, 0.187	3
790-18	M-F Standoff, 4-40, 0.375, Hex	2
785-927	M-F Standoff, 4-40, 0.625	3
761-79	Cap Vinyl, Black, round	2

### Case Parts

Part Number	Description	Qty
46652-3	Top Case only (for units with serial number 409999 and below)	1
46652-8	Top Case only (for units with serial number 409999 and above)	1
46653-3	Bottom Case only	1
48231-3	Battery Door	1
790-509 790-510 48241	Battery Door Latch (3 pieces)	1
790-511	Battery Door Latch Receptacle	1
46655-1	Case Corner Bumpers	4
46662	LCD Retainer Plate	1
48241	Foam, LCD Corners	9
48278	Foam, LCD Window	1
46659	Foam, LCD Backing	1
46661	Foam, Keypad Backing	1
720-19	Cable Clamp	1
790-515	Spring, Battery Compartment	1
58237	ID Label, Model MT8212A	1

## 23. Customer Service

To locate the nearest Anritsu Customer Service Center, please refer to the Anritsu web page:

<http://www.anritsu.com/Contact.asp>



**Anritsu**

Discover What's Possible™